

### SPECIFICATIONS

<b>Flue Length (min.)</b>	4.5m - from the top of the fireplace
<b>Min. Flue Height above Roof</b>	1.4m
<b>Compliance</b>	Tested to <i>AS/NZS2918 Appendix F</i>
<b>Flue Type</b>	Natural Draught - Direct Vent
<b>Flue Size</b>	150mm Exhaust/200mm Inlet/250mm outer
<b>Flue Shield</b>	Not required
<b>Flue Clearances to Combustibles</b>	25mm from 250mm outer flue liner to any combustible materials
<b>Flue Extensions</b>	Triple Skin only

### FLUE HEIGHT

Flue height should be the greater of; the minimum flue length and the requirements of *AS/NZS2918 External Clearances*. The min. flue length is **4.5m** from the top of the fireplace to the flue cowl, with a min. of 1.4m above the roof surface. *AS/NZS2918 External Clearances* are to ensure that the flue cowl is not obstructed from any adjacent buildings or structures. Refer to the Installation Manual for clearances. *Please note: a decrease in flue length will increase the chance of smoke spillage, while an increase in length can reduce the burn time.*

### FLUE RESTRAINT

The outer flue should be restrained by way of compatible brackets connected to the outer casing and an adjacent roof or wall. Space these brackets is at a min. 3m intervals.

### FLUE DETAILS

### FLUE OPTIONS

**Inbuilt Wood Fire Classic Flue Kit** comprises a 4.5m triple skin flue system extending from the Fireplace and Zero Clearance Kit to the final cowl location. The kit comprises an exhaust flue, intake flue and additional flue liner (150/200/250mm Ø). **Escea Designer Wood Fire Flue**, a cylindrical shroud with perforated elements, encasing a classic flue kit to provide a sleek roof line aesthetic. The Escea Designer Wood Fire Flue Kit is available in stainless steel or black finishes, and is supplementary to a classic flue kit.

*\*For specific flue detailing refer to the requisite indoor wood fireplace on the Technical page of the Escea website: [www.escea.com/technical](http://www.escea.com/technical)*

### FLOOR AND WALL PENETRATIONS

Where the flue penetrates a floor above the fireplace, or a wall, this must be configured with a triple skin ceiling penetration kit or wall penetration kit. Triple skin ceiling/floor penetration kits can be supplied by Escea. 45° Wall Spigot plates are combined with flue offset kits for external wall flue penetrations.

### OFFSETS/BENDS AND EXTENSIONS

Flue extensions and 45° offsets/bends are available as double skin or triple skin variants depending on the model selected and the location of the offset within the flue pathway. Flue offsets can reduce draught within the flue pathway; it is recommended to avoid where possible or allow for an extension of the flue length.

### FLUE FLASHING

Flue flashing design and installation is the responsibility of the specifier or the installer. Choose a detail and/or component that will meet all relevant Building Code requirements and manufactured from a heat resistant material.

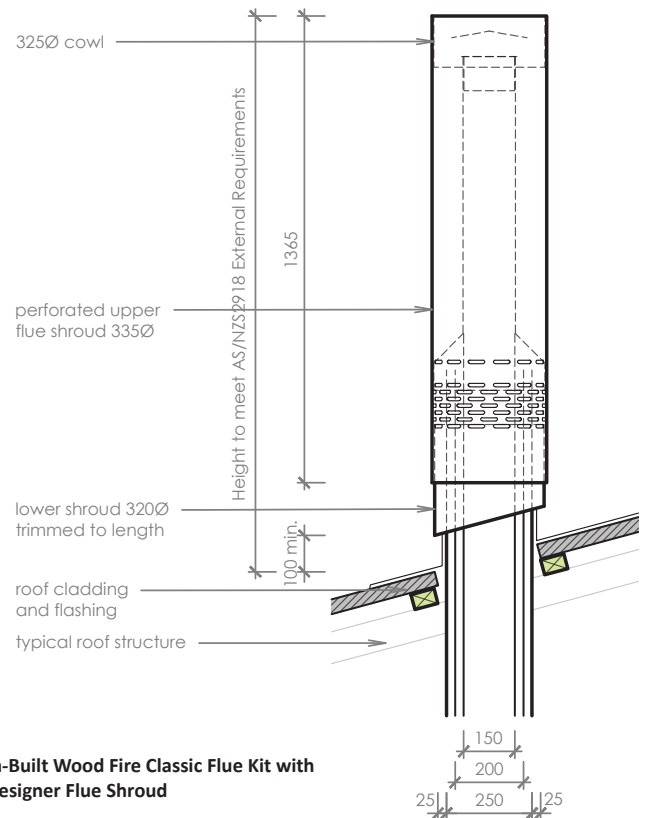
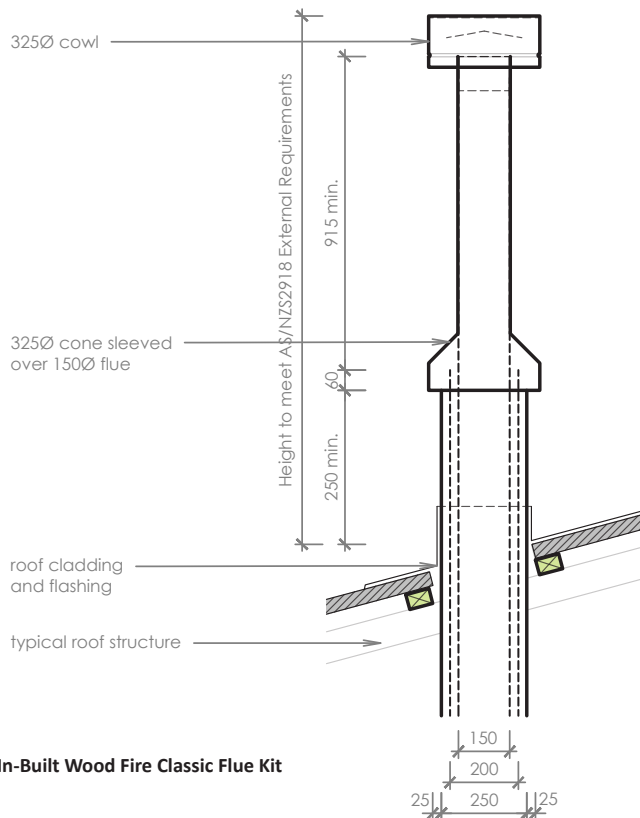

Install in accordance with *AS/NZS2918* and the *Escea TC950 Install Manual*.  
**For Installation methods not covered in this document please contact:**  
 Email: [aa@escea.com](mailto:aa@escea.com) PH (NZ): 0800 17 3000 PH (AU): 1800 460 832

Install Manual and CAD files are available via the QR Code or link:  
[www.escea.com/technical](http://www.escea.com/technical)



Disclaimer:  
 Dimensions provided are indicative and may not consider all site-specific variations or installation needs. Verify dimensions on-site before manufacturing or construction.